

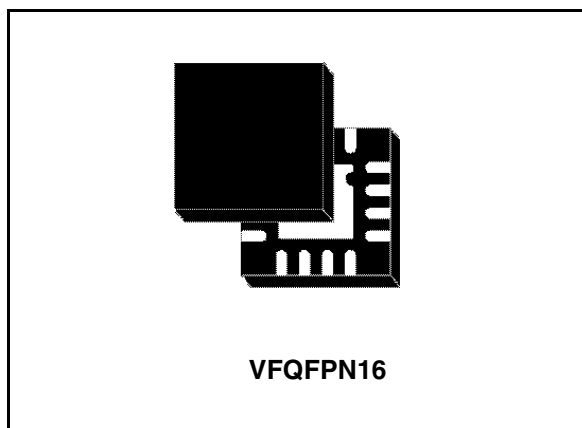


## L6924D

### Battery charger system with integrated power switch for Li-ION/Li-POLYMER

#### Features

- Fully integrated solution, with a power MOSFET, reverse blocking diode, sense resistor, and thermal protection
- Ideal for coke and graphite anode single-cell Li-ION packs
- Both linear and quasi-pulse operation
- Closed loop thermal control
- USB BUS-compatible
- Programmable charge current up to 1A
- Programmable pre-charge current
- Programmable end-of-charge current
- Programmable pre-charge voltage threshold
- Programmable charge timer
- Programmable output voltage at 4.1V and 4.2V, with  $\pm 1\%$  output voltage accuracy
- (NTC) or (PTC) thermistor interface for battery temperature monitoring and protection
- Flexible charge process termination
- Status outputs to drive LEDs or to interface with a host processor
- Small VFQFPN 16-leads package (3mm x 3mm)



#### Applications

- PDAs
- Handheld devices
- Cellular phones
- Digital cameras
- Standalone chargers
- USB-Powered chargers

Table 1. Device summary

Order codes	Package	Packaging
L6924D	VFQFPN16	Tube
L6924D013TR	VFQFPN16	Tape & Reel

# Contents

<b>1</b>	<b>Device description</b> .....	<b>4</b>
<b>2</b>	<b>Pins description and connection diagrams</b> .....	<b>5</b>
	2.1 Pin description .....	6
<b>3</b>	<b>Maximum ratings</b> .....	<b>7</b>
	3.1 Absolute maximum ratings .....	7
	3.2 Thermal data .....	7
<b>4</b>	<b>Electrical specifications</b> .....	<b>8</b>
	4.1 Electrical characteristics .....	8
<b>5</b>	<b>Block diagram</b> .....	<b>10</b>
<b>6</b>	<b>Operation description</b> .....	<b>11</b>
	6.1 Linear mode .....	13
	6.2 Quasi-pulse mode .....	14
<b>7</b>	<b>Applications information: charging process</b> .....	<b>17</b>
	7.1 Charging process flow chart .....	17
	7.2 Pre-charge current .....	18
	7.3 Pre-charge voltage .....	19
	7.4 Fast charge current .....	19
	7.5 End-of-charge current .....	20
	7.6 Recharge flow chart .....	21
	7.7 Recharge threshold .....	21
	7.8 Maximum charging time .....	22
	7.9 Termination modes .....	23

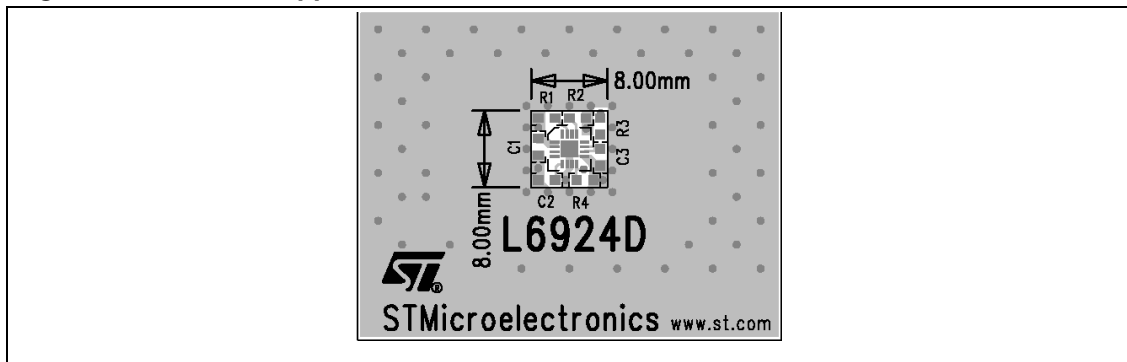
---

<b>8</b>	<b>Application information: monitoring and protection</b> .....	<b>24</b>
8.1	NTC thermistor .....	25
8.2	Battery absence detection .....	28
8.3	Status pins .....	29
8.4	Shutdown .....	29
<b>9</b>	<b>Additional applications information</b> .....	<b>30</b>
9.1	Selecting input capacitor .....	30
9.1.1	Selecting output capacitor .....	30
9.2	Layout guidelines and demoboard description .....	30
<b>10</b>	<b>Application ideas</b> .....	<b>34</b>
10.1	USB battery charger .....	34
<b>11</b>	<b>Package mechanical data</b> .....	<b>35</b>
<b>12</b>	<b>Revision history</b> .....	<b>37</b>

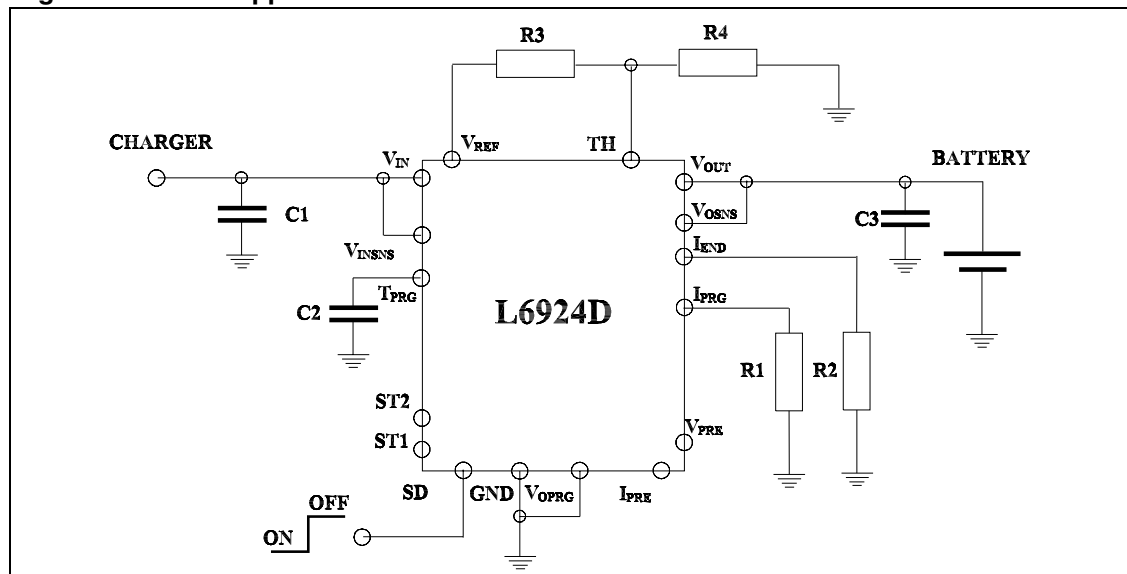
# 1 Device description

The L6924D is a fully monolithic battery charger dedicated to single-cell Li-Ion/Polymer battery packs. It is the ideal solution for space-limited applications, like PDAs, handheld equipment, cellular phones, and digital cameras. It is designed with BCD6 technology and integrates all of the power elements (the Power MOSFET, reverse blocking diode and the sense resistor) in a small VFQFPN16 3mm x 3mm package. When an external voltage regulated wall adapter is used, the L6924D works in Linear Mode, and charges the battery in a Constant Current/Constant Voltage(CC/CV) profile. Moreover, when a current-limited adapter is used, the device can operate in Quasi-Pulse Mode, dramatically reducing the power dissipation. Regardless of the charging approach, a closed loop thermal control avoids device overheating. The device has an operating input voltage ranging from 2.5V to 12V. The L6924D allows the user to program many parameters, such as pre-charge current, fast-charge current, pre-charge voltage threshold, end-of-charge current threshold, and charge timer. The L6924D offers two open collector outputs for diagnostic purposes, which can be used to either drive two external LEDs or communicate with a host microcontroller. Finally, the L6924D also provides very flexible control of the charge process termination and Gas Gauge capability, as well as other functions, such as checking for battery presence, and monitoring and protecting the battery from unsafe thermal conditions.

**Figure 1. Minimum application size**

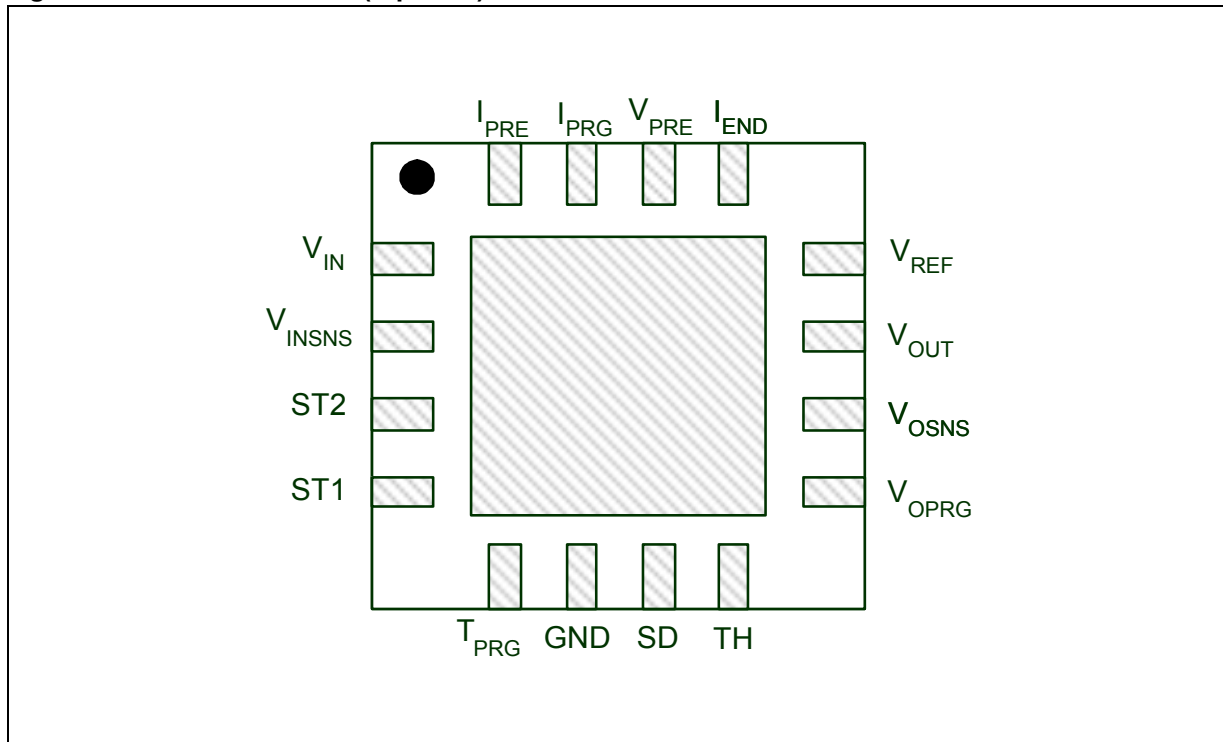


**Figure 2. Basis application schematic**



## 2 Pins description and connection diagrams

Figure 3. Pins connection (top view)



## 2.1 Pin description

Table 2. Pin functions

Pin	I/O	Name	Pin description
1	I	V <sub>IN</sub>	Input pin of the power stage.
2	I	V <sub>INSNS</sub>	Supply voltage pin of the signal circuitry. The operating input voltage range is from 2.5V and 12V, and the start-up threshold is 4V.
3-4	O	ST <sub>2</sub> -ST <sub>1</sub>	Open-collector status pins.
5	I	T <sub>PRG</sub>	Maximum charging time program pin. It must be connected with a capacitor to GND to fix the maximum charging time, see <a href="#">Chapter 7.8: Maximum charging time on page 22</a>
6	-	GND	Ground pin.
7	I	SD	Shutdown pin. When connected to GND enables the device; when floating disables the device.
8	I	TH	Temperature monitor pin. It must be connected to a resistor divider including an NTC or PTC resistor. The charge process is disabled if the battery temperature (sensed through the NTC or PTC) is out of the programmable temperature window see <a href="#">Chapter 8.1: NTC thermistor on page 25</a> .
9	I	V <sub>OPRG</sub>	Output voltage selection pin. If is it floating, V <sub>OUT</sub> = 4.1V. If is it connected to GND, V <sub>OUT</sub> = 4.2V.
10	I	V <sub>OSNS</sub>	Output voltage sense pin. It senses the battery voltage to control the voltage regulation loop.
11	O	V <sub>OUT</sub>	Output pin. (connected to the battery)
12	O	V <sub>REF</sub>	External reference voltage pin.(reference voltage is 1.8V±2%)
13	I/O	I <sub>END</sub>	Charge termination pin. A resistor connected from this pin to GND fixes the charge termination current threshold I <sub>ENDTH</sub> : if I < I <sub>ENDTH</sub> , the charger behaves according to the V <sub>PRE</sub> status (see <a href="#">Chapter 7.5: End-of-charge current on page 20</a> ). The voltage across the resistor is proportional to the current delivered to the battery (Gas Gauge function).
14	I	V <sub>PRE</sub>	Multifunction pin. A resistor connected to GND allows the user to adjust the pre-charge voltage threshold V <sub>PRETH</sub> . – If the pin is floating, V <sub>PRETH</sub> = 2.8V. If the voltage on V <sub>PRE</sub> pin is lower than 0.8V, V <sub>PRETH</sub> = 2.8V and the charge is not automatically terminated when I < I <sub>ENDTH</sub> . – If the voltage on V <sub>PRE</sub> goes lower than 0.5V (edge sensitive), the maximum charging time is reset.
15	I	I <sub>PRG</sub>	Charge current program pin. A resistor connected from this pin to GND, fixes the fast charge current value (I <sub>CHG</sub> ), with an accuracy of 7%.
16	I	I <sub>PRE</sub>	Pre-charge current program pin. If the pin is floating I <sub>PRETH</sub> is equal to 10% of I <sub>CHG</sub> . If I <sub>PRETH</sub> has to be programmed at a different value, the pin has to be connected to GND or V <sub>REF</sub> through a resistor see <a href="#">Chapter 7.2: Pre-charge current on page 18</a> .

### 3 Maximum ratings

Stressing the device above the rating listed in the “Absolute Maximum Ratings” table may cause permanent damage to the device. These are stress ratings only and operation of the device at these or any other conditions above those indicated in the Operating sections of this specification is not implied. Exposure to Absolute Maximum Rating conditions for extended periods may affect device reliability. Refer also to the STMicroelectronics SURE Program and other relevant quality documents.

#### 3.1 Absolute maximum ratings

**Table 3. Absolute maximum ratings**

Symbol	Parameter	Value	Unit
$V_{IN}$	Input voltage	-0.3 to 16	V
$V_{INSNS}$ , SD	Input voltage	-0.3 to $V_{IN}$	V
$V_{OUT}$ , $V_{OSNS}$	Output voltage	-0.3 to 5	V
ST1, ST2	Output voltage	-0.3 to 6	V
	Output current	30	mA
$V_{REF}$ , TH, $I_{END}$ , $I_{PRG}$ , $V_{PRE}$ , $I_{PRE}$ , $V_{OPRG}$ , $T_{PRG}$ , GND		-0.3 to 4	V
ST1 and TH pins	Maximum Withstanding Voltage Range Test Condition: CDFAEC-Q100-002 (Normal “Human Body Model” Acceptance Criteria Performance)	±1.5	kV
Other pins		±2	kV

#### 3.2 Thermal data

**Table 4. Thermal data**

Symbol	Parameter	Value	Unit
$R_{thJA}$	Thermal resistance junction to ambient <sup>(1)</sup>	75	°C/W
$T_{STG}$	Storage temperature range	-55 to 150	°C
$T_J$	Junction temperature range	-40 to 125	°C
$P_{TOT}$	Power dissipation at T= 70°C	TBD	W

1. Device mounted on Demo board

## 4 Electrical specifications

### 4.1 Electrical characteristics

$T_J = 25^\circ\text{C}$ ,  $V_{IN} = 5\text{V}$ , unless otherwise specified

**Table 5. Electrical characteristics**

Symbol	Parameter	Test condition	Min	Typ	Max	Unit
$V_{IN}^{(1)}$	Operating input voltage		2.5		12	V
	Start up threshold				4.1	V
$I_{IN}^{(1)}$	Supply current	Charging mode ( $R_{PRG} = 24\text{K}$ )		1.8	2.5	mA
		Shutdown mode ( $R_{PRG} = 24\text{K}$ )		60	80	$\mu\text{A}$
$I_{SINK}$	Current flowing from $V_{OUT}$	Shutdown mode ( $R_{PRG} = 24\text{K}$ )			500	nA
		Stand by mode ( $R_{PRG} = 24\text{K}$ ) ( $V_{IN} = 2.5\text{V} < V_{BATTERY}$ )			500	nA
$V_{OUT}^{(1)}$	Battery regulated voltage	$V_{OPRG}$ at $V_{IN}$	4.06	4.1	4.14	V
		$V_{OPRG}$ at GND	4.16	4.2	4.24	V
$I_{CHG}$	Charge current	$R_{PRG} = 24\text{K}$	450	490	525	mA
		$R_{PRG} = 12\text{K}$	905	975	1045	mA
$I_{PRECH}$	Pre-Charge current [default value = 10% $I_{CHG}$ ]	$I_{PRE}$ floating $R_{PRG} = 24\text{K}$	41	49	56	mA
$I_{PRECH}$	Pre-Charge current	$R_{PRE} = 62\text{K}$ to GND; $R_{PRG} = 24\text{K}$	57	67	78	mA
$I_{PRECH}$	Pre-Charge current	$R_{PRE} = 39\text{K}$ to $V_{REF}$ ; $R_{PRG} = 24\text{K}$	29.5	35	40.1	mA
$V_{PRETH}$	Pre-Charge voltage threshold [default]	$V_{PRE} = V_{PRETH}$ Default = Floating	2.7	2.8	2.9	V
$V_{PRETH}$	Pre-Charge voltage threshold	$R_{VPRE} = 13\text{K}$ ; $R_{PRG} = 12\text{K}$	2.87	3.03	3.19	V
$V_{PRETH}$	Pre-Charge voltage threshold [default]. Charge termination disabled		2.7	2.8	2.9	V
$I_{ENDTH}$	Termination current	$R_{END} = 3\text{K}3$	12	16	20	mA
$T_{MAXCH}^{(2)}$	Maximum charging time	$C_{TPRG} = 10\text{nF}$ $R[I_{PRG}] = 24\text{K}$		3		hours



Table 5. Electrical characteristics (continued)

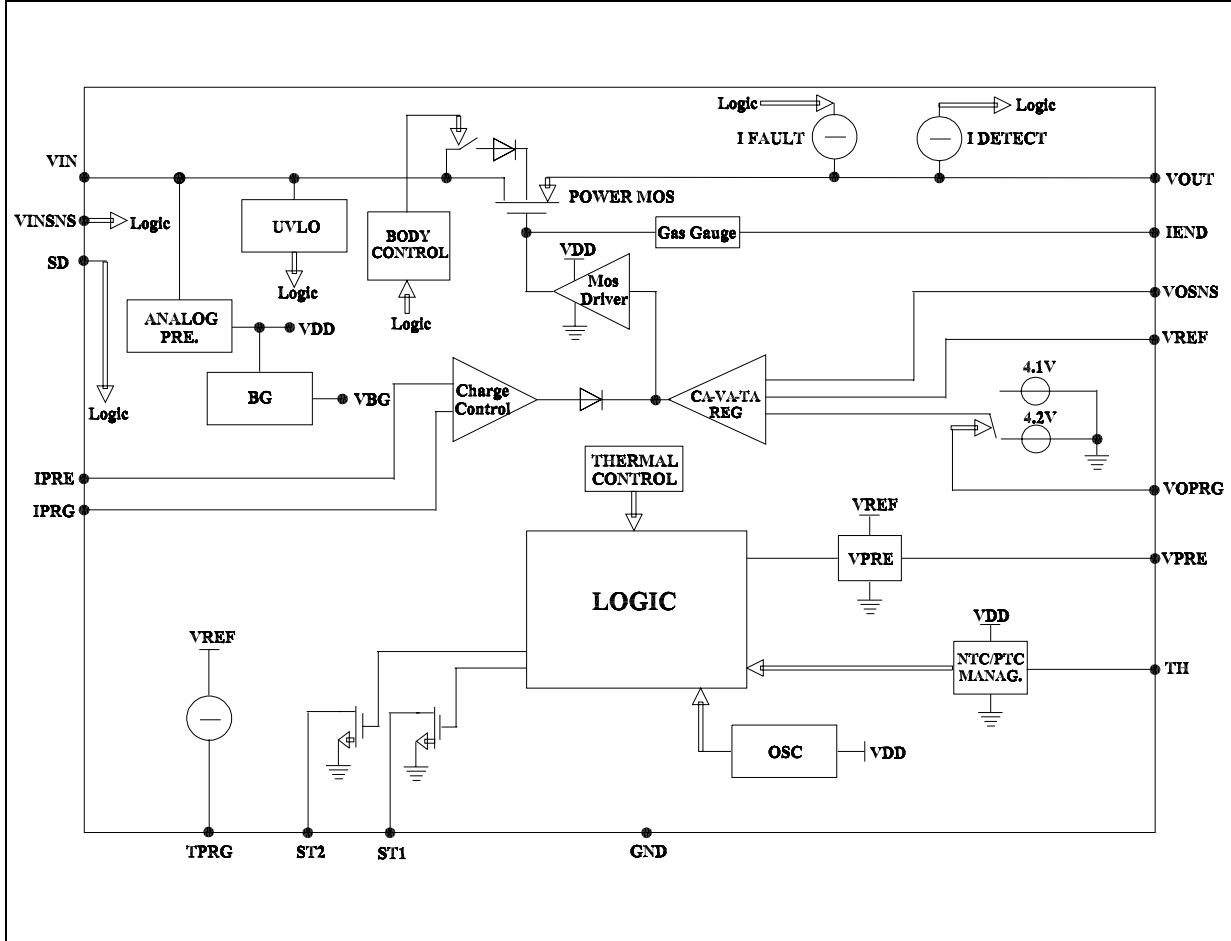
Symbol	Parameter	Test condition	Min	Typ	Max	Unit
$T_{MAXCH}$ (2)	Maximum charging time accuracy	$C_{TPRG} = 5.6nF$ $R_{PRG} = 24K$		10%		
$SD_{TH}$	Shutdown threshold high				2	V
	Shutdown threshold low		0.4			V
ST1,2	Output status sink current	Status on		10		mA
$R_{DS(on)}$	Power MOSFET resistance	$R_{DS(on)} @ I_{CHG} = 500mA$		280	380	m $\Omega$
TH	NTC pin hot threshold voltage		10	12.5	15	% $V_{REF}$
	NTC pin cold threshold voltage		40	50	60	% $V_{REF}$

1.  $T_J$  from  $-40^{\circ}C$  to  $125^{\circ}C$ .

2. Guaranteed by design.

# 5 Block diagram

Figure 4. Block diagram



## 6 Operation description

The L6924D is a fully integrated battery charger that allows a very compact battery management system for space limited applications. It integrates in a small package, all the power elements: power MOSFET, reverse blocking diode and the sense resistor.

It normally works as a linear charger when powered from an external voltage regulated adapter. However, thanks to its very low minimum input voltage (down to 2.5V) the L6924D can also work as a Quasi-Pulse charger when powered from a current limited adapter. To work in this condition, is enough to set the device's charging current higher than the adapter one ([Chapter 7.4 on page 19](#)). The advantage of the linear charging approach is that the device has a direct control of the charging current and so the designer needn't to rely on the upstream adapter. However, the advantage of the Quasi-Pulse approach is that the power dissipated inside the portable equipment is dramatically reduced.

Regards the charging approach, the L6924D charges the battery in three phases:

- **Pre-Charge constant current:** in this phase (active when the battery is deeply discharged) the battery is charged with a low current.
- **Fast-Charge constant current:** in this phase the device charges the battery with the maximum current.
- **Constant Voltage:** when the battery voltage is closed to the selected output voltage, the device starts to reduce the current, until the charge termination is done.

The full flexibility is provided by:

- Programmable pre-charging current and voltage thresholds ( $I_{PRETH}$  and  $V_{PRETH}$ ) ([Chapter 7.2 on page 18](#), [Chapter 7.3 on page 19](#)).
- Programmable fast-charging current ( $I_{CHG}$ ) ([Chapter 7.4 on page 19](#)).
- Programmable end of charge current threshold ( $I_{ENDTH}$ ) ([Chapter 7.5 on page 20](#)).
- Programmable end of charge timer ( $T_{MAXCH}$ ) ([Chapter 7.8 on page 22](#)).

If the full flexibility is not required and a smaller number of external components is preferred, default values of  $I_{PRETH}$  and  $V_{PRETH}$  are available leaving the respective pins floating.

- If a PTC or NTC resistor is used, the device can monitor the battery temperature in order to protect the battery from operating in unsafe thermal conditions.
- Beside the good thermal behavior guaranteed by low thermal resistance of the package, additional safety is provided by the built-in temperature control loop. The IC monitors continuously its junction temperature. When the temperature reaches approximately 120°C, the thermal control loop starts working, and reduces the charging current, in order to keep the IC junction temperature at 120°C.
- Two open collector outputs are available for diagnostic purpose (status pins ST1 and ST2). They can be also used to drive external LEDs or to interface with a microcontroller.
- The voltage across the resistor connected between  $I_{END}$  and GND gives information about the actual charging current (working as a Gas Gauge), and it can be easily fed into a  $\mu C$  ADC.

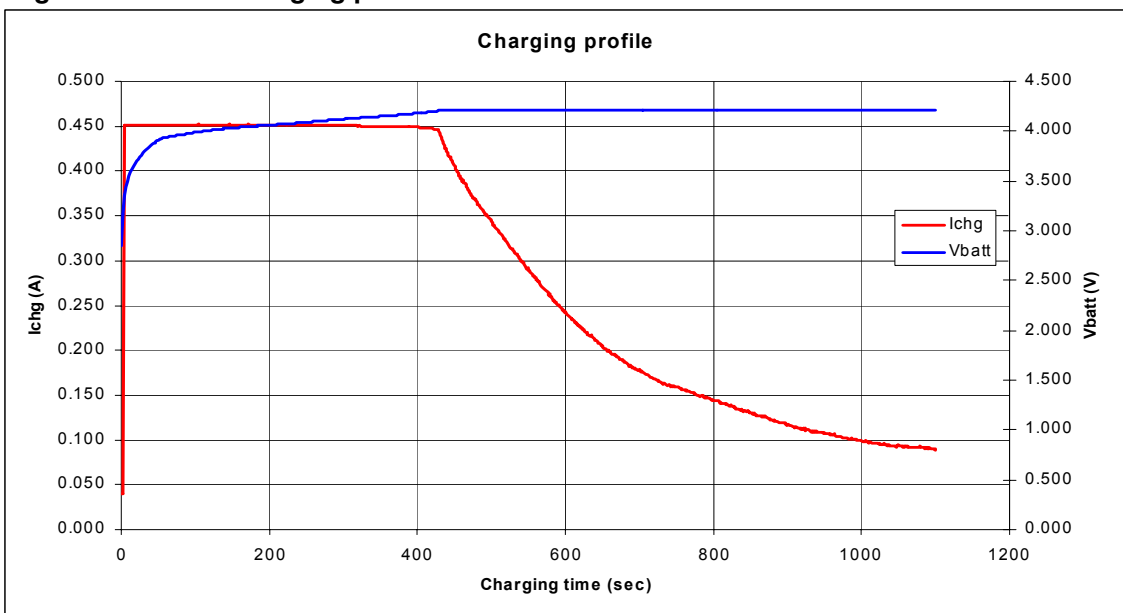
When the  $V_{PRE}$  pin is not used to program the Pre-Charge voltage threshold, it has two different functions:

- If the voltage across  $V_{PRE}$  pin is lower than 0.8V, when  $I < I_{ENDTH}$ , the end of charge is notified by the status pin, but the charging process is not disabled. The charge process ends when the maximum charging time expires.
- If pin  $V_{PRE}$  goes lower than 0.5V the timer is reset on the falling edge.

Battery disconnection control is provided thanks to the differentiated sensing and forcing output pins. A small current is sunk and forced through  $V_{OUT}$ . If  $V_{OSNS}$  doesn't detect the battery, the IC goes into a standby mode.

Figure 5 shown the real charging profile of a Li-Ion battery, with a Fast Charge current of 450mA ( $R_{PRG} = 26K\Omega$ ),

Figure 5. Li-Ion charging profile



## 6.1 Linear mode

When operating in Linear Mode, the device works in a way similar to a linear regulator with a constant current limit protection.

It charges the battery in three phases:

- Pre-charging current ("Pre-Charge" phase).
- Constant current ("Fast-Charge" phase).
- Constant voltage ("Voltage Regulation" phase).

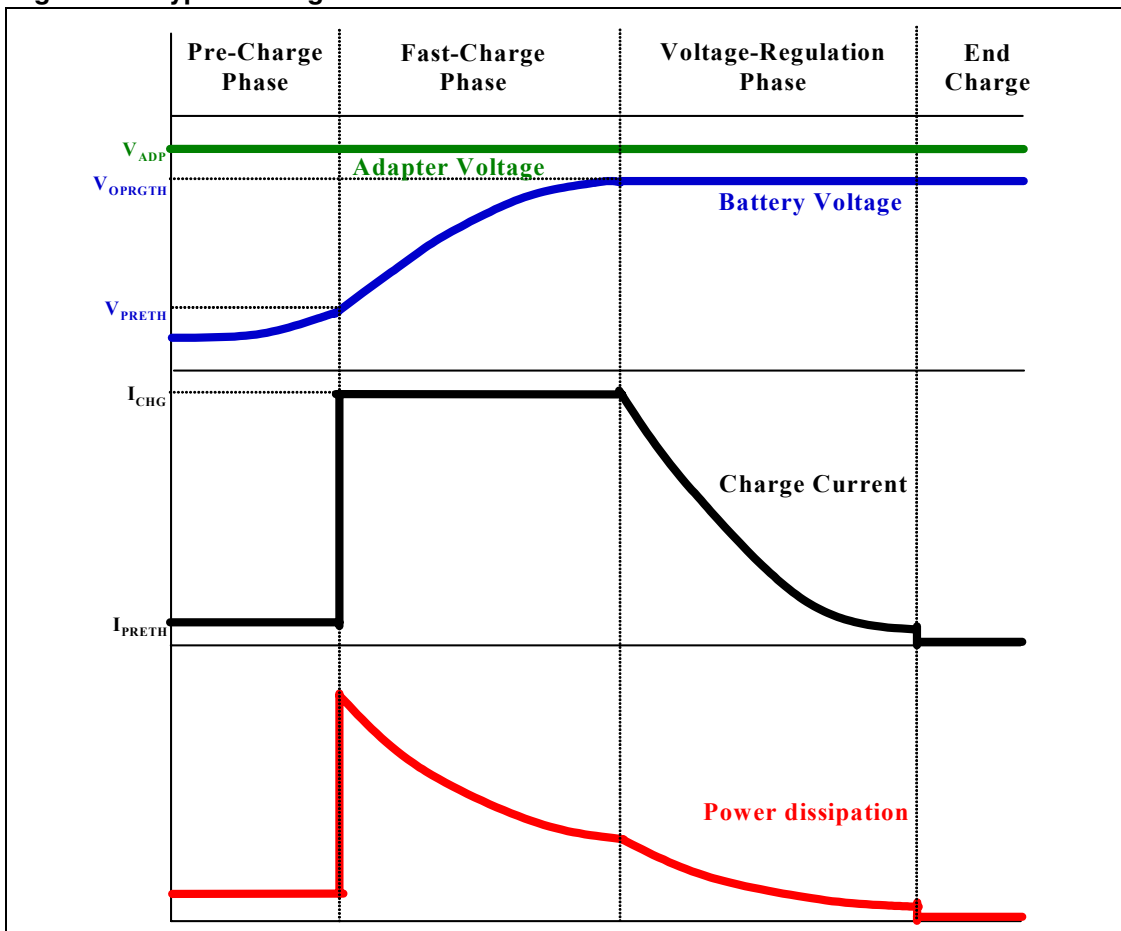
$V_{ADP}$  is the output voltage of the upstream AC-DC adapter that is, in turn, the input voltage of the L6924D. If the battery voltage is lower than a set pre-charge voltage ( $V_{PRETH}$ ), the pre-charge phase takes place. The battery is pre-charged with a low current  $I_{PRE}$  ([Chapter 7.2 on page 18](#)).

When the battery voltage goes higher than  $V_{PRETH}$ , the battery is charged with the Fast Charge current  $I_{CHG}$ , set with an external resistor ([Chapter 7.4 on page 19](#)).

Finally, when the battery voltage is close to the regulated output voltage  $V_{OPRGTH}$  (4.1V or 4.2V), the voltage regulation phase takes place and the charging current is reduced. The charging process usually is terminated when the charging current reaches a set value or when a charging timer expires ([Chapter 7.9 on page 23](#)).

[Figure 6](#) shows the different phases.

**Figure 6. Typical charge curves in linear mode**



The worst case in power dissipation occurs when the device starts the Fast-Charge Phase. In fact, the battery voltage is at its minimum value. In this case, this is the maximum difference between the adapter voltage and battery voltage, and the charge current is at its maximum value.

The power dissipated is given by the following formula:

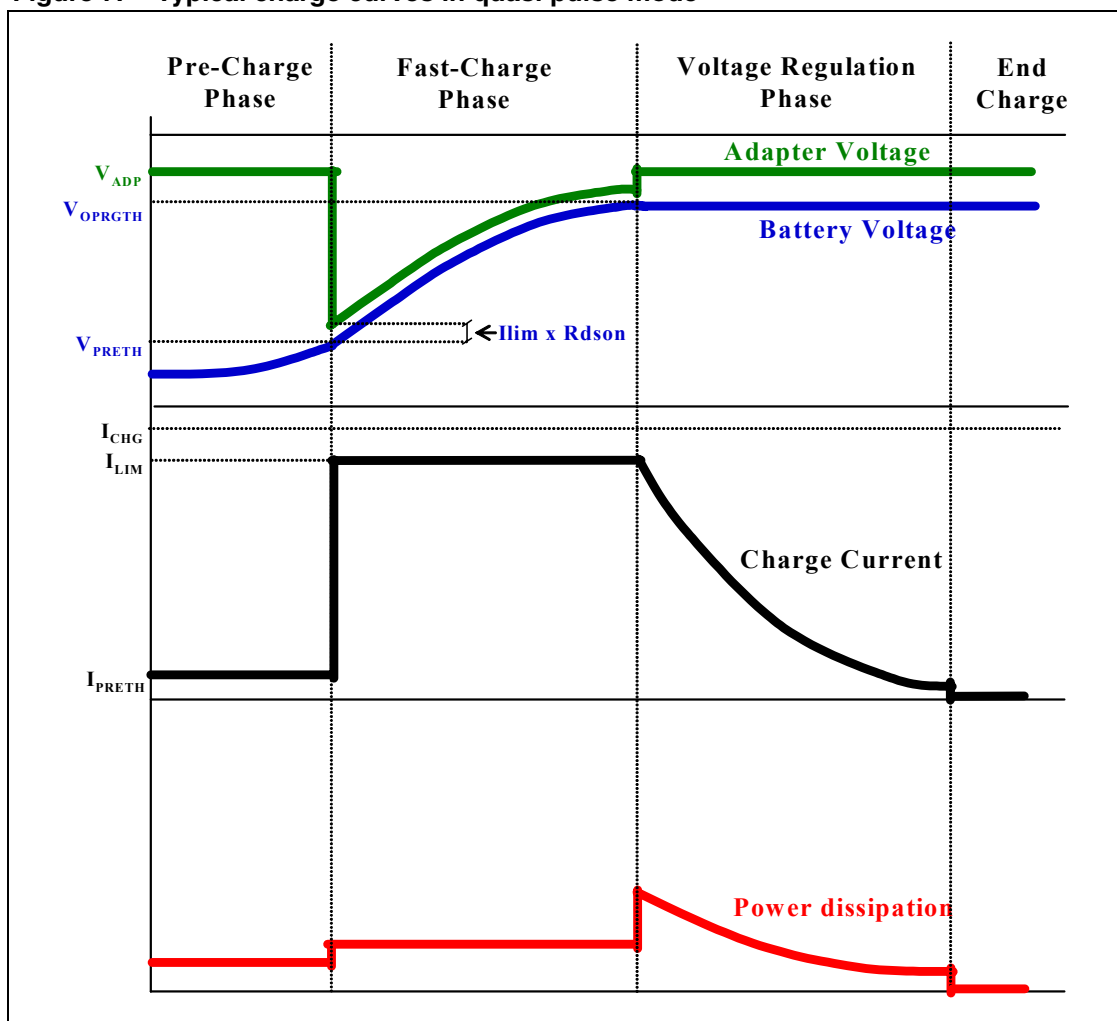
$$P_{DIS} = (V_{ADP} - V_{BAT}) \times I_{CHG} \quad \text{Eq. 7-1}$$

The higher the adapter voltage is, the higher the power dissipated. The maximum power dissipated depends on the thermal impedance of the device mounted on board.

## 6.2 Quasi-pulse mode

The Quasi-Pulse Mode can be used when the system can rely on the current limit of the upstream adapter to charge the battery. In this case,  $I_{CHG}$  must be set higher than the current limit of the adapter. In this mode, the L6924D charges the battery with the same three phases as in Linear Mode, but the power dissipation is greatly reduced as shown in [Figure 7](#).

**Figure 7. Typical charge curves in quasi pulse mode**



The big difference is due to the fact that  $I_{CHG}$  is higher than the current limit of the adapter. During the Fast-Charge Phase, the output voltage of the adapter drops and goes down to the battery voltage plus the voltage drop across the power MOSFET of the charger, as shown in the following equation:

$$V_{IN} = V_{ADP} = V_{BAT} + \Delta V_{MOS} \quad \text{Eq. 7-2}$$

Where  $\Delta V_{MOS}$  is given by:

$$\Delta V_{MOS} = R_{DS(on)} \times I_{LIM} \quad \text{Eq. 7-3}$$

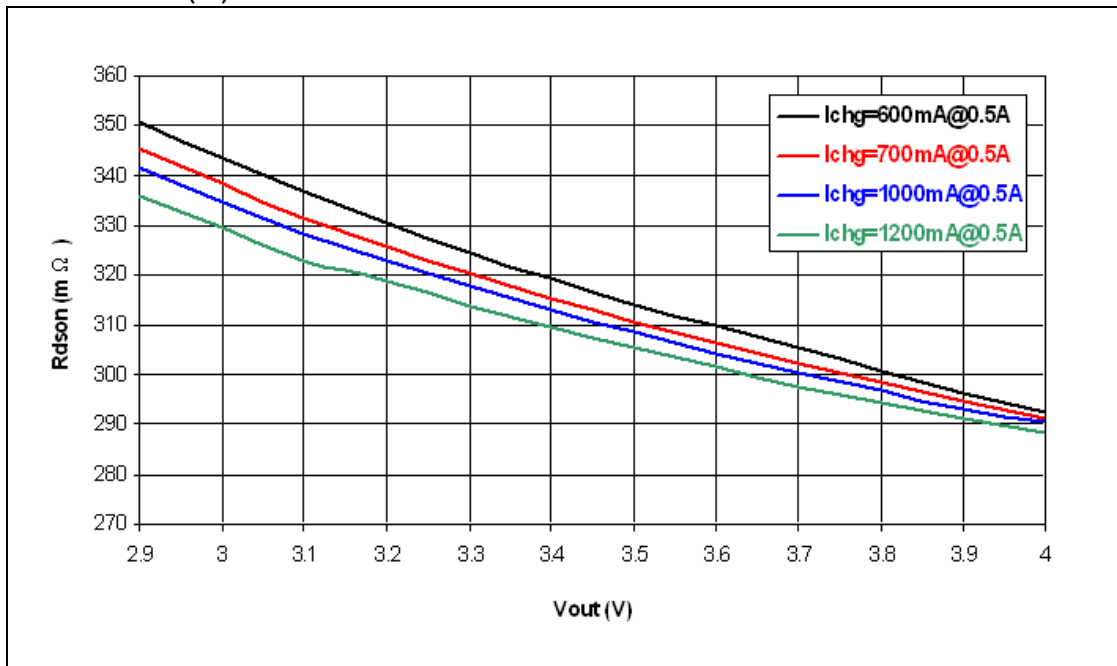
Where,

$I_{LIM}$  = current limit of the wall adapter, and  $R_{DS(on)}$  = resistance of the power MOSFET.

The difference between the set charge current and the adapter limit should be high enough to minimize the  $R_{DS(on)}$  value (and the power dissipation). This makes the control loop completely unbalanced and the power element is fully turned on.

[Figure 8](#) shows the  $R_{DS(on)}$  values for different output voltage and charging currents for an adapter current limit of 500mA.

**Figure 8.  $r_{DS(on)}$  curves vs charging current and output voltage**



Neglecting the voltage drop across the charger ( $\Delta V_{MOS}$ ) when the device operates in this condition, its input voltage is equal to the battery one, and so a very low operating input voltage (down to 2.5V) is required. The power dissipated by the device during this phase is:

$$P_{CH} = R_{DS(on)} \times I_{LIM}^2 \quad \text{Eq: 7-4}$$

When the battery voltage approaches the final value, the charger gets back the control of the current, reducing it. Due to this, the upstream adapter exits the current limit condition and its output goes up to the regulated voltage  $V_{ADP}$ . This is the worst case in power dissipation:

$$P_{DIS} = (V_{ADP} - V_{BAT}) \times I_{LIM} \quad \text{Eq: 7-5}$$

In conclusion, the advantage of the linear charging approach is that the designer has the direct control of the charge current, and consequently the application can be very simple. The drawback is the high power dissipation.

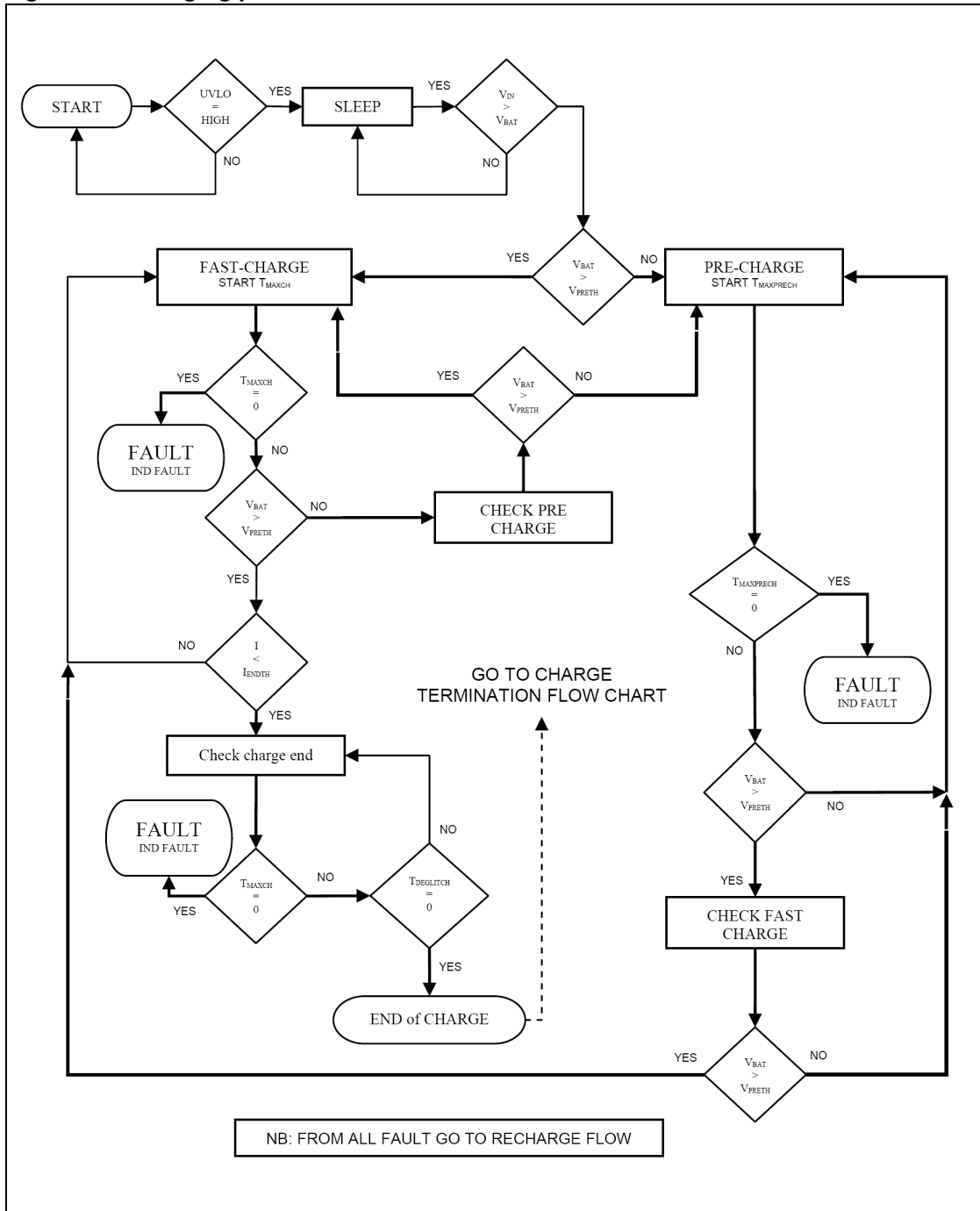
The advantage of the Quasi-Pulse charging method is that the power dissipated is dramatically reduced. The drawback is that a dedicated upstream adapter is required.



# 7 Applications information: charging process

## 7.1 Charging process flow chart

Figure 9. Charging process flow chart

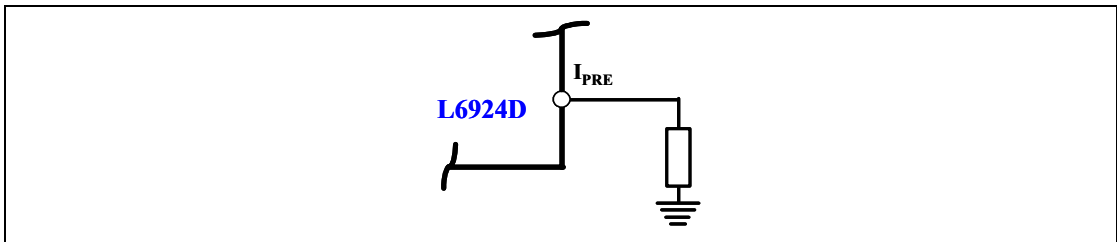


## 7.2 Pre-charge current

The L6924D allows pre-charging the battery with a low current when the battery voltage is lower than a specified threshold ( $V_{PRETH}$ ). The Pre-charge current has a default value equal to 10% of the fast-charge current (see [Chapter 7.2: Pre-charge current on page 18](#)). However it can be adjusted by connecting a resistor from the  $I_{PRE}$  pin to GND or  $V_{REF}$  [Figure 10](#). When the resistor is connected from  $I_{PRE}$  pin and GND, the current is higher than the default value. The  $R_{PRE}$  value is given by:

$$R_{PRE} = \frac{V_{BG}}{\frac{I_{PRECH}}{K_{PRE}} - \frac{V_{BG}}{R_{PRG}}} \quad \text{Eq: 8-1}$$

Figure 10.  $I_{PRE}$  pin connection

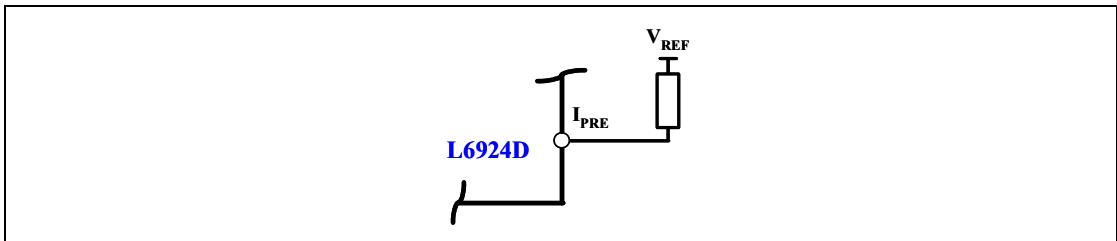


When  $R_{PRE}$  is connected to  $V_{REF}$ , the current is lower than the default value.  $V_{REF}$  is the external reference equal to 1.8V,  $V_{BG}$  is the internal reference equal to 1.23V and  $K_{PRE}$  is a constant equal to 950. [Figure 11](#)

The relationship is shown in the equation 8.2:

$$R_{PRE} = \frac{V_{REF} - V_{BG}}{\frac{V_{BG}}{R_{PRG}} - \frac{I_{PRECH}}{K_{PRE}}} \quad \text{Eq: 8-2}$$

Figure 11.  $I_{PRE}$  pin connection

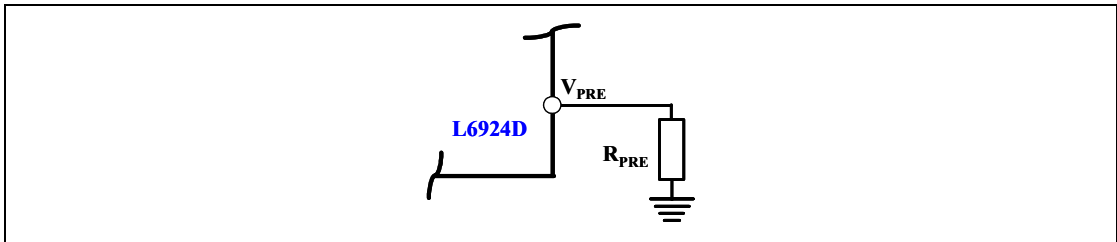


### 7.3 Pre-charge voltage

If the  $V_{PRE}$  pin is floating, a default value of  $V_{PRETH}$  is set, equal to 2.8V ( $V_{PRETHDefault}$ ). Otherwise, the device offers the possibility to program this value, with a resistor connected between the  $V_{PRE}$  pin and GND [Figure 12](#). In this case, the  $R_{VPRE}$  is given by the equation 8.3:

$$R_{VPRE} = R_{PRG} \times \left( \frac{V_{PRETH}}{V_{PRETHDefault}} \right) \text{ Eq: 8-3}$$

**Figure 12.  $V_{PRE}$  pin connection**



Where  $R_{VPRE}$  is the resistor between  $V_{PRE}$  and GND, and  $R_{PRG}$  is the resistor used to set the charge current (see [Section 7.4: Fast charge current](#)), and  $V_{PRETH}$  is the selected threshold.

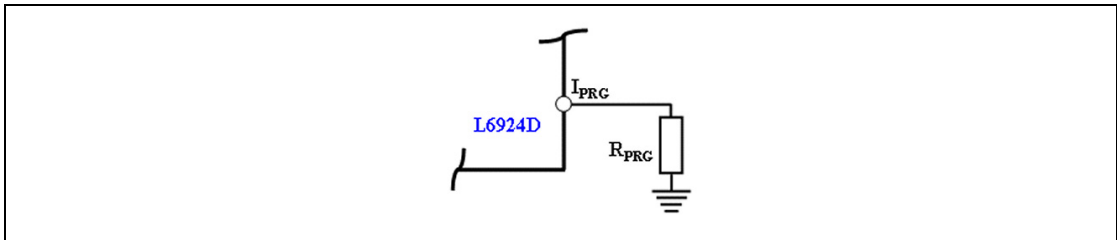
A safety timer is also present. If the battery voltage doesn't rise over  $V_{PRETH}$ , before this time is expired, a fault is given (see [Section 7.8: Maximum charging time](#)). If at the beginning of the charge process, the battery voltage is higher than the  $V_{PRETH}$ , the Pre-Charge phase is skipped.

### 7.4 Fast charge current

When the battery voltage reaches the Pre-charge voltage threshold ( $V_{PRETH}$ ), the L6924D starts the Fast-charge Phase. In this phase, the device charges the battery with a constant current,  $I_{CHG}$ , programmable by an external resistor that sets the charge current with an accuracy of 7% [Figure 13](#). The formula used to select the  $R_{PRG}$  as follows:

$$R_{PRG} = V_{BG} \times \left( \frac{K_{PRG}}{I_{CHG}} \right) \text{ Eq: 8-4}$$

**Figure 13.  $I_{PRG}$  pin connection**



Where  $K_{PRG}$  is a constant, equal to 9500.

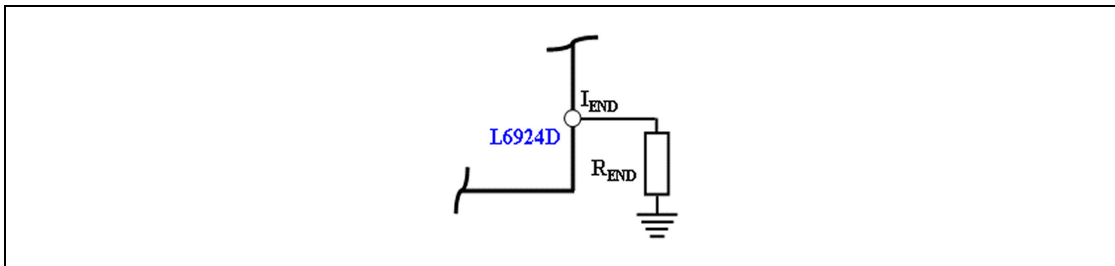
During this phase, the battery voltage increases until it reaches the programmed output voltage. A safety timer is also present. If this time expires, a fault is given ([Section 7.8: Maximum charging time](#)).

## 7.5 End-of-charge current

When the charge voltage approaches the selected value (4.1V or 4.2V), the Voltage Regulation phase takes place. The charge current starts to decrease until it goes lower than a programmable end value,  $I_{ENDTH}$ , depending on an external resistor connected between the  $I_{END}$  pin and GND [Figure 14](#). The formula that describes this relation as follows:

$$R_{END} = V_{MIN} \times \left( \frac{K_{END}}{I_{ENDTH}} \right) \quad \text{Eq: 8-5}$$

**Figure 14.**  $I_{END}$  pin connection



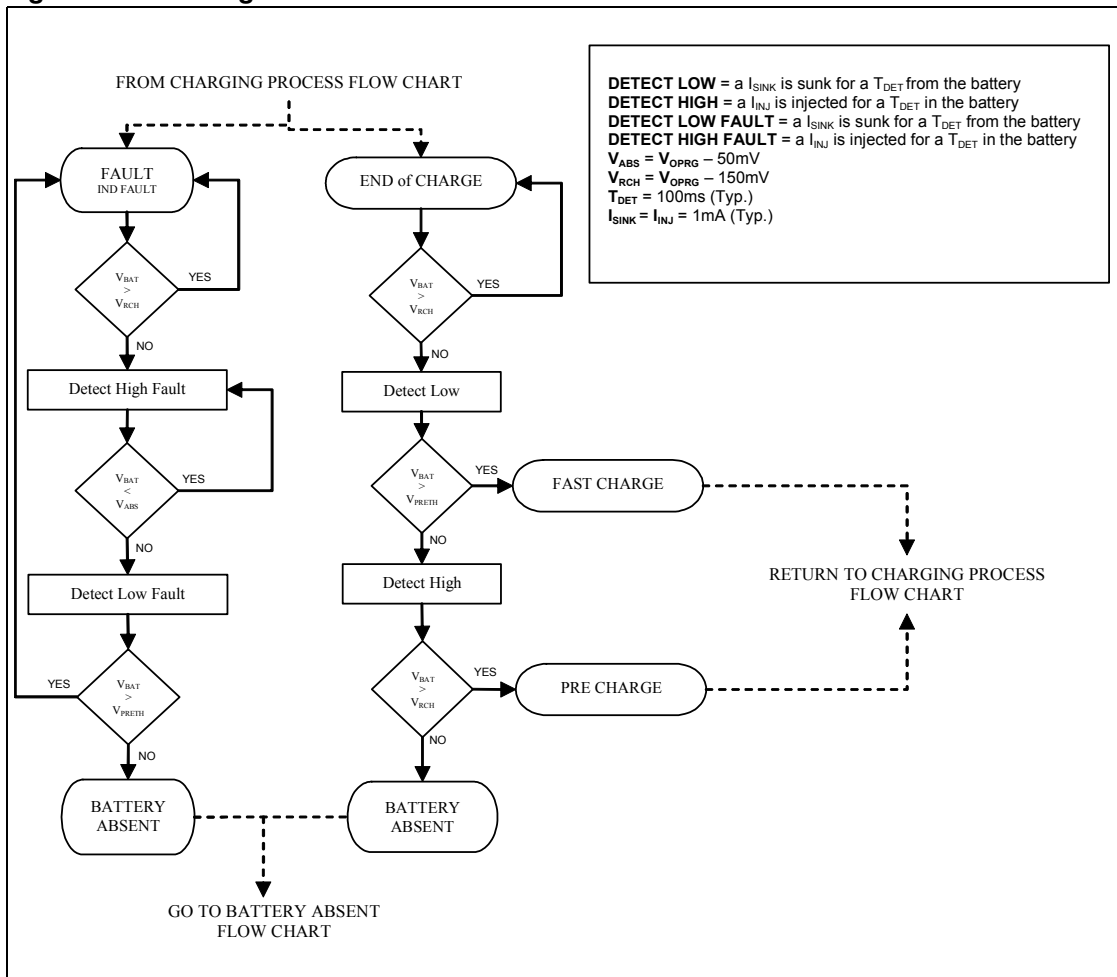
Where  $K_{END}$  is 1050; and  $V_{MIN}$  is 50mV.

Typically, this current level is used to terminate the charge process. However, it is also possible to disable the charge termination process based on this current level ([Chapter 7.9 on page 23](#)).

This pin is also used to monitor the charge current, because the current injected in  $R_{END}$  is proportional to  $I_{CHG}$ . The voltage across  $R_{END}$  can be used by a microcontroller to check the charge status like a gas gauge.

## 7.6 Recharge flow chart

Figure 15. Recharge flow chart



## 7.7 Recharge threshold

When, from an End-of-Charge condition, the battery voltage goes lower than the recharging threshold ( $V_{RCH}$ ), the device goes back in charging state. The value of the recharge threshold is  $V_{OPRG} - 150mV$ .

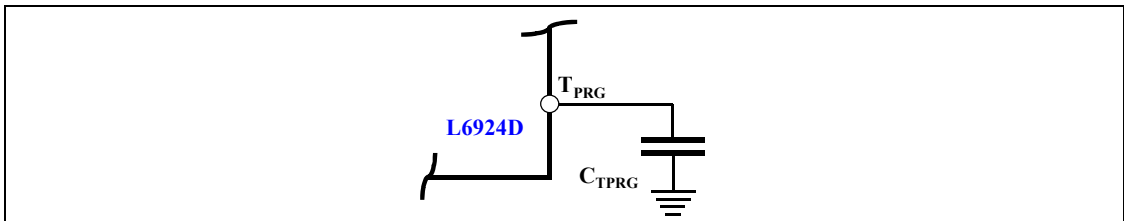
## 7.8 Maximum charging time

To avoid the charging of a dead battery for a long time, the L6924D has the possibility can be set a maximum charging time starting from the beginning of the Fast-Charge Phase. This timer can be set with a capacitor, connected between the T<sub>PRG</sub> pin and GND. The C<sub>TPRG</sub> is the external capacitor (in nF) and is given by the following formula:

$$C_{TPRG} = \left( \frac{\frac{T_{MAXCH}}{K_T} \times \frac{V_{BG}}{R_{PRG}}}{V_{REF}} \right) \times 10^9 \quad \text{Eq: 8-6}$$

*Note:* The maximum recommended C<sub>TPRG</sub> value must be less than 50 nF.

**Figure 16. T<sub>PRG</sub> pin connection**



Where,

$$V_{REF} = 1.8V,$$

$$K_T = 279 \times 10^5,$$

$$V_{BG} = 1.23V, \text{ and}$$

T<sub>MAXCH</sub> is the charging time given in seconds.

If the battery does not reach the End-of-Charge condition before the time expires, a fault is issued.

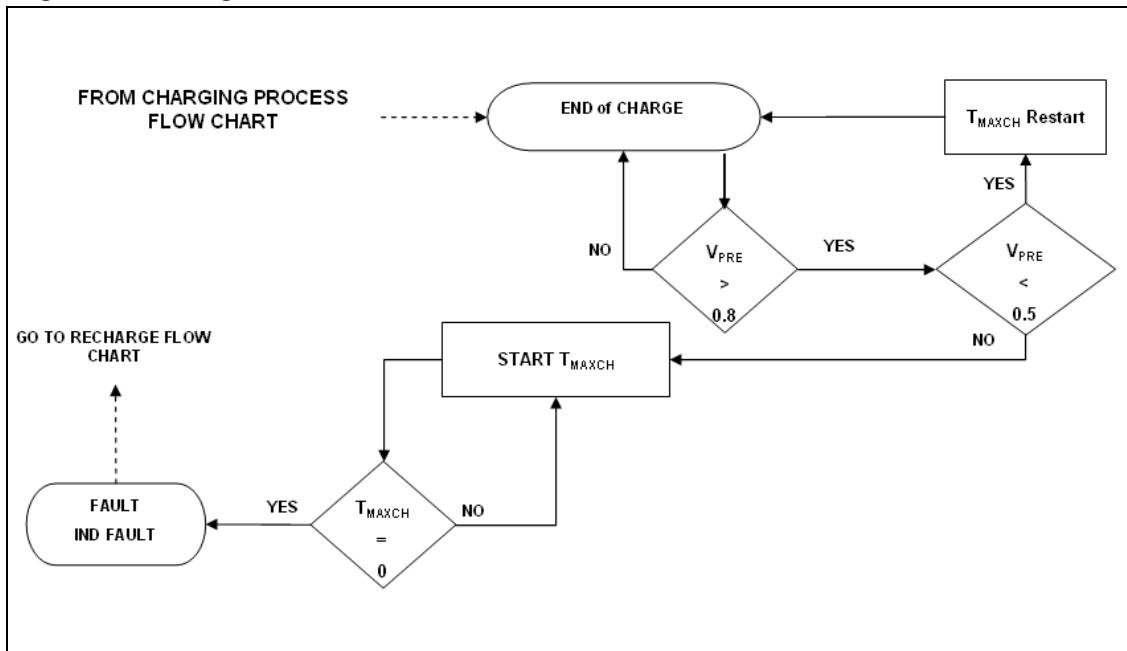
Also during the Pre-Charge Phase there is a safety timer, given by:

$$T_{MAXPRECH} = \frac{1}{8} \times T_{MAXCH} \quad \text{Eq: 8-7}$$

If this timer expires and the battery voltage is still lower than V<sub>PRETH</sub>, a fault signal is generated, and the charge process is terminated.

## 7.9 Termination modes

Figure 17. Charge termination flow chart



As shown in [Figure 17](#), it is possible to set an end of charge current  $I_{\text{ENDTH}}$  connecting a resistor between the  $I_{\text{END}}$  pin and GND. When the charge current goes down to this value, after de-glitch time, the status pins notify that the charge process is complete. This de-glitch time expressed as:

$$T_{\text{DEGLITCH}} = \frac{T_{\text{MAXCH}}}{220} \quad \text{Eq: 8-9}$$

However, the termination of the charger process depends on the status of the  $V_{\text{PRE}}$  pin:

- If the voltage at the  $V_{\text{PRE}}$  pin is higher than 0.8V, the charger process is actually terminated when the charge current reaches  $I_{\text{ENDTH}}$ .
- If the voltage at  $V_{\text{PRE}}$  pin goes lower than 0.8V, the charge process does not terminate, and the charge current can go lower than  $I_{\text{ENDTH}}$ . The status pins notify the End-of-Charge as a fault condition, but the device continues the charge. When the  $T_{\text{MAXCH}}$  is elapsed, the charge process ends, and a fault condition is issued.
- If the voltage on  $V_{\text{PRE}}$  pin is lower than 0.8V during the Pre-charge Phase, the device sets the  $V_{\text{PRETHDefault}}$  automatically.
- If the voltage at the  $V_{\text{PRE}}$  pin goes lower than 0.5V (edge sensitive), the timer is reset, both in Pre-Charge and in Fast-Charge Phase.

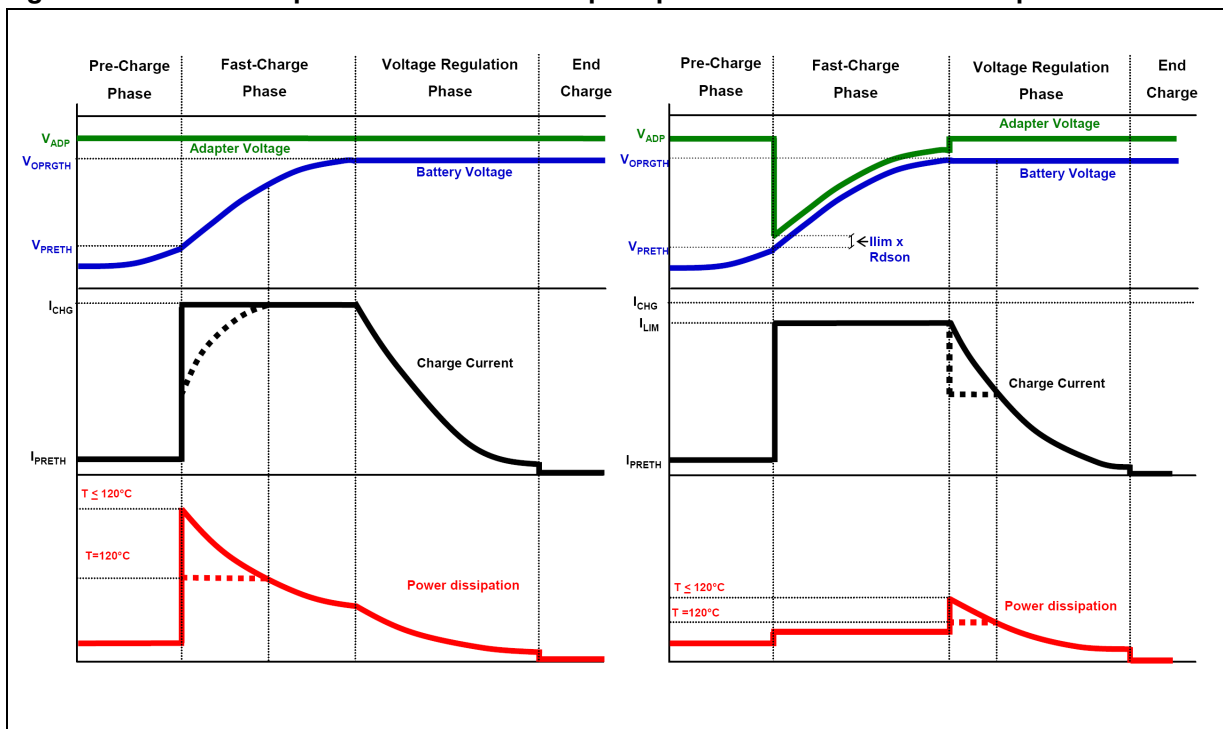
## 8 Application information: monitoring and protection

The L6924D uses a VFQFPN 3mm x 3mm 16-pin package with an exposed pad that allows the user to have a compact application and good thermal behavior at the same time. The L6924D has a low thermal resistance because of the exposed pad (approximately 75°C/W, depending on the board characteristics). Moreover, a built-in thermal protection feature prevents the L6924D from having thermal issues typically present in a linear charger.

Thermal Control is implemented with a thermal loop that reduces the charge current automatically when the junction temperature reaches approximately 120°C. This avoids further temperature rise and keeps the junction temperature constant. This simplifies the thermal design of the application as well as protects the device against over-temperature damage.

The figure above shows how the thermal loop acts (with the dotted lines), when the junction temperature reaches 120°C..

Figure 18. Power dissipation both linear and quasi pulse mode with thermal loop



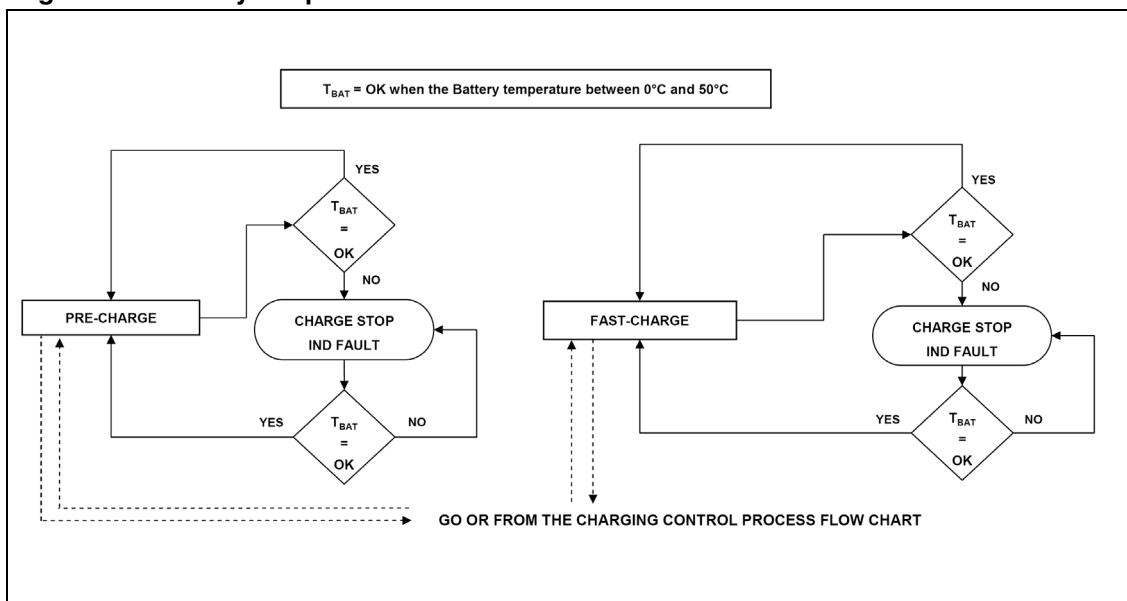


### 8.1 NTC thermistor

The device allows designers to monitor the battery temperature by measuring the voltage across an NTC or PTC resistor. Li-Ion batteries have a narrow range of operating temperature, usually from 0°C to 50°C. This window is programmable by an external divider which is comprised of an NTC thermistor connected to GND and a resistor connected to  $V_{REF}$ . When the voltage on the TH pin exceeds the minimum or maximum voltage threshold (internal window comparator), the device stops the charge process, and indicates a fault condition through the status pin.

When the voltage (and thus, the temperature), returns to the window range, the device re-starts the charging process. Moreover, there is a hysteresis for both the upper and lower thresholds, as shown in [Figure 20](#)

**Figure 19. Battery temperature control flow chart**



Note:  $T_{BAT} = OK$  when the Battery temperature between 0°C and 50°C

Figure 20. Voltage window with hysteresis On TH

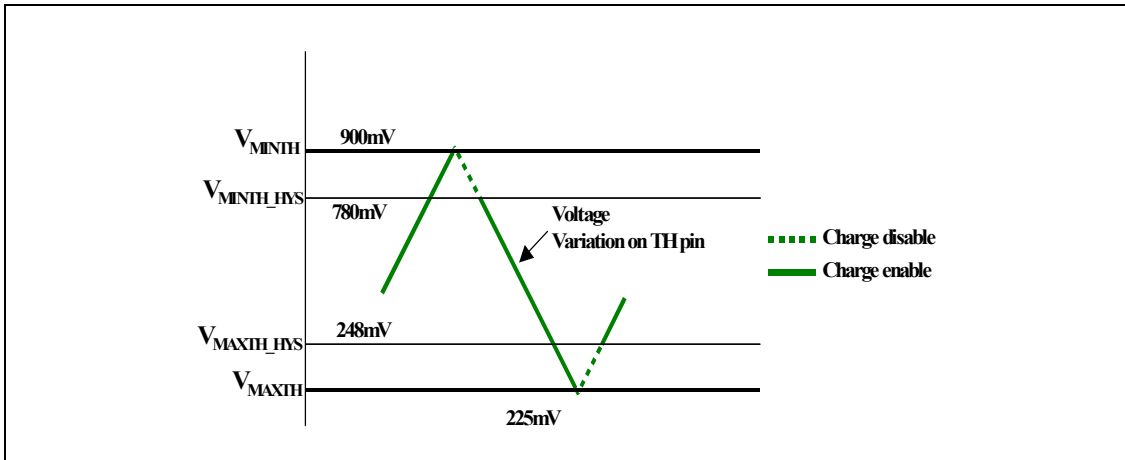
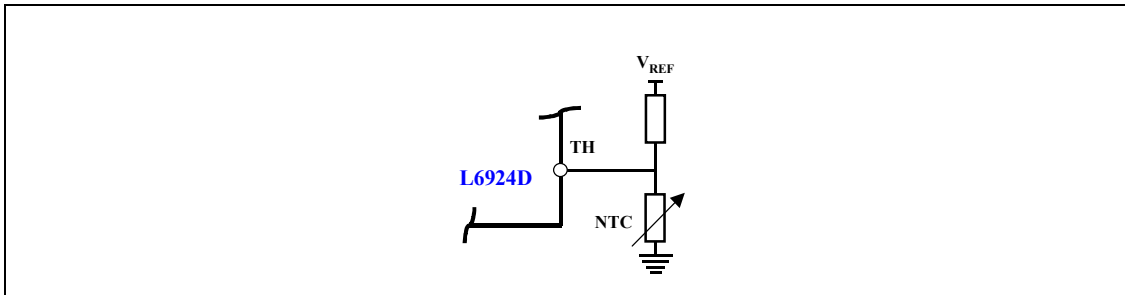


Figure 21. Pin connection



When the TH pin voltage rises and exceeds the  $V_{MINTH} = 50\%$  of  $V_{REF}$  (900mV typ), the L6924D stops the charge, and indicates a fault by the status pins. The device re-starts to charge the battery, only when the voltage at the TH pin goes under  $V_{MINTH\_HYS} = 780\text{mV}$  (typ).

For what concerns the high temperature limit, when the TH pin voltage falls under the  $V_{MAXTH} = 12.5\%$  of  $V_{REF}$  (225mV Typ.), the L6924D stops the charge until the TH pin voltage rises at the  $V_{MAXTH\_HYS} = 248\text{mV}$  (Typ.).

When the battery is at the low temperature limit, the TH pin voltage is 900mV. The correct resistance ratio to set the low temperature limit at 0°C can be found with the following formula:

$$V_{MINTH} = V_{REF} \times \frac{R_{NTC0^\circ C}}{R_{UP} + R_{NTC0^\circ C}} \quad \text{Eq: 9-1}$$

Where  $R_{UP}$  is the pull-up resistor,  $V_{REF}$  is equal to 1.8V, and  $R_{NTC0^\circ C}$  is the value of the NTC at 0°C. Since at the low temperature limit  $V_{MINTH} = 900\text{mV}$ :

$$0.9 = 1.8 \times \frac{R_{NTC0^\circ C}}{R_{UP} + R_{NTC0^\circ C}} \quad \text{Eq: 9-2}$$

It follows that:

$$R_{NTC0^\circ C} = R_{UP} \quad \text{Eq: 9-3}$$

Similarly, when the battery is at the high temperature limit, the TH pin voltage is 225mV. The correct resistance ratio to set the high temperature limit at 50°C can be found with the following formula:

$$V_{MAXTH} = V_{REF} \times \frac{R_{NTC50^{\circ}C}}{R_{UP} + R_{NTC50^{\circ}C}} \quad \text{Eq: 9-4}$$

Where  $R_{NTC50^{\circ}C}$  is the value of the NTC at 50°C. Considering  $V_{MAXTH} = 225\text{mV}$  it follows that:

$$0.225 = 1.8 \times \frac{R_{NTC50^{\circ}C}}{R_{UP} + R_{NTC50^{\circ}C}} \quad \text{Eq: 9-5}$$

Consequently:

$$R_{NTC50^{\circ}C} = \frac{R_{UP}}{7} \quad \text{Eq: 9-6}$$

Based on equations 9-3 and 9-6, it derives that:

$$\frac{R_{NTC0^{\circ}C}}{R_{NTC50^{\circ}C}} = 7 \quad \text{Eq: 9-7}$$

The temperature hysteresis can be estimated by the formula:

$$T_{HYS} = \frac{V_{TH} - V_{TH\_HYS}}{V_{TH} \times NTC_T} \quad \text{Eq: 9-8}$$

Where  $V_{TH}$  is the pin voltage threshold on the rising edge,  $V_{TH\_HYS}$  is the pin voltage threshold on the falling edge, and  $NTC_T$  (- %/°C) is the negative temperature coefficient of the NTC at temperature (T) expressed in % resistance change per °C. For  $NTC_T$  values, see the characteristics of the NTC manufacturers (e.g. the 2322615 series by VISHAY). At the low temperature, the hysteresis is approximately:

$$T_{HYS0^{\circ}C} = \frac{900\text{mV} - 780\text{mV}}{900\text{mV} \times NTC0^{\circ}C} \quad \text{Eq: 9-9}$$

Obviously at the high temperature hysteresis is:

$$T_{HYS50^{\circ}C} = \frac{225\text{mV} - 248\text{mV}}{225\text{mV} \times NTC50^{\circ}C} \quad \text{Eq: 9-10}$$

Considering typical values for  $NTC0^{\circ}C$  and  $NTC50^{\circ}C$ , the hysteresis is:

$$T_{HYS0^{\circ}C} = \frac{900\text{mV} - 780\text{mV}}{900\text{mV} \times 0.051} \cong 2.5^{\circ}C \quad \text{Eq: 9-11}$$

And:

$$T_{HYS50^{\circ}C} = \frac{225\text{mV} - 248\text{mV}}{225\text{mV} \times 0.039} \cong -2.5^{\circ}C \quad \text{Eq: 9-12}$$

If a PTC connected to GND is used, the selection is the same as above, the only difference is when the battery temperature increases, the voltage on the TH pin increases, and vice versa. For applications that do not need a monitor of the battery temperature, the NTC can be replaced with a simple resistor whose value is one half of the pull-up resistor  $R_{UP}$ .

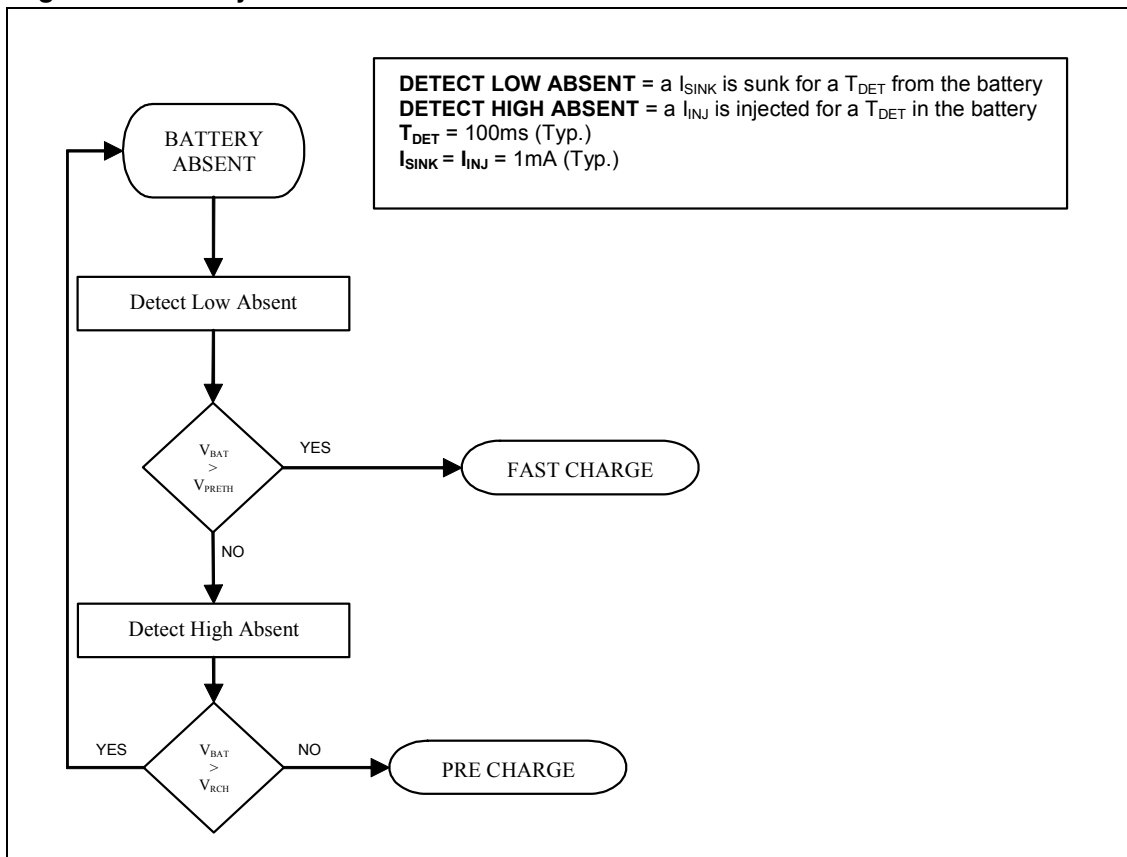
In this case, the voltage at the TH pin is always inside the voltage window, and the charge is always enabled.

## 8.2 Battery absence detection

This feature provides a battery absent detection scheme to detect the removal or the insertion of the battery. If the battery is removed, the charge current falls below the  $I_{ENDTH}$ . At the end of de-glitch time, a detection current  $I_{DETECT}$ , equal to 1mA, is sunk from the output for a time of  $T_{DETECT}$ . The device checks the voltage at the output. If it is below the  $V_{PRETH}$ , a current equal to  $I_{DETECT}$  is injected in the output capacitor for a  $T_{DETECT}$ , and it is checked to see if the voltage on the output goes higher than  $V_{ABS}$  (the value is  $V_{OPRGTH}-50mV$ ). If the battery voltage changes from  $V_{PRETH}$  to  $V_{ABS}$  and vice versa in a  $T_{DETECT}$  time, it means that no battery is connected to the charger. The  $T_{DETECT}$  is expressed by::

$$T_{DETECT} = \frac{T_{MAXCH}}{54 \times 10^3} \quad \text{Eq: 9-13}$$

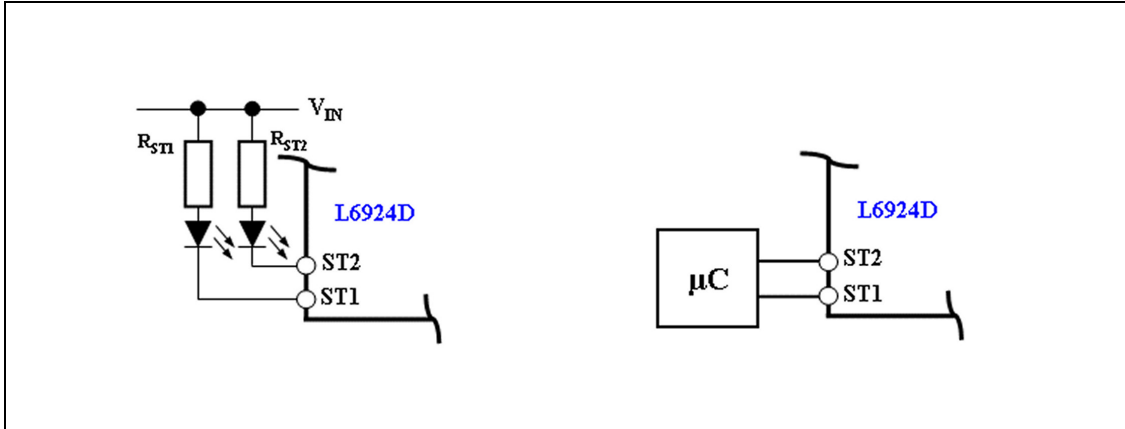
Figure 22. Battery absent detection flow chart



### 8.3 Status pins

To indicate various charger status conditions, there are two open-collector output pins, ST1 and ST2. These status pins can be used either to drive status LEDs, connected with an external power source, by a resistor, or to communicate to a host processor. These pins must never be connected to the  $V_{IN}$  when it overcomes their absolute value (6V).

**Figure 23. ST1 and ST2 connection with LEDs Or  $\mu C$**



**Table 6. Status LEDs Indications**

Charge condition	Description	ST1	ST2
Charge in progress	When the device is in Pre-Charge or fast-Charge status	ON	OFF
Charge done	When the charging current goes lower than the $I_{ENDTH}$	OFF	ON
Stand By mode	When the input voltage goes under $V_{BAT} - 50mV$	OFF	OFF
Bad battery temperature	When the voltage on the TH pin is out of the programmable window, in accordance with the NTC or PTC thermistor	ON	ON
Battery absent	When the battery pack is removed	ON	ON
Over time	When $T_{MAXCH}$ or $T_{MAXPRECH}$ is expired	ON	ON

### 8.4 Shutdown

The L6924D has a shutdown pin; when the pin is connected to GND, the device is operating. When the pin is left floating, the device enters in shutdown mode, the consumption from the input is dramatically reduced to  $60\mu A$  (typ.). In this condition,  $V_{REF}$  is turned OFF.

## 9 Additional applications information

### 9.1 Selecting input capacitor

In most applications, a 1µF ceramic capacitor, placed close to the V<sub>IN</sub> and V<sub>INSN</sub> pins can be used to filter the high frequency noise.

#### 9.1.1 Selecting output capacitor

Typically, 1µF ceramic capacitor placed close to the V<sub>OUT</sub> and V<sub>OUTSN</sub> pin is enough to keep voltage control loop stable. This ensures proper operation of battery absent detection in removable battery pack applications.

### 9.2 Layout guidelines and demoboard description

The thermal loop keeps the device at a constant temperature of approximately 120°C which in turn, reduces I<sub>CHG</sub>. However, in order to maximize the current capability, it is important to ensure a good thermal path. Therefore, the exposed pad must be properly soldered to the board and connected to the other layer through thermal vias. The recommended copper thickness of the layers is 70µm or more.

The exposed pad must be electrically connected to GND. [Figure 24](#) shows the thermal image of the board with the power dissipation of 1W. In this instance, the temperature of the case is 89°C, but the junction temperature of the device is given by the following formula:

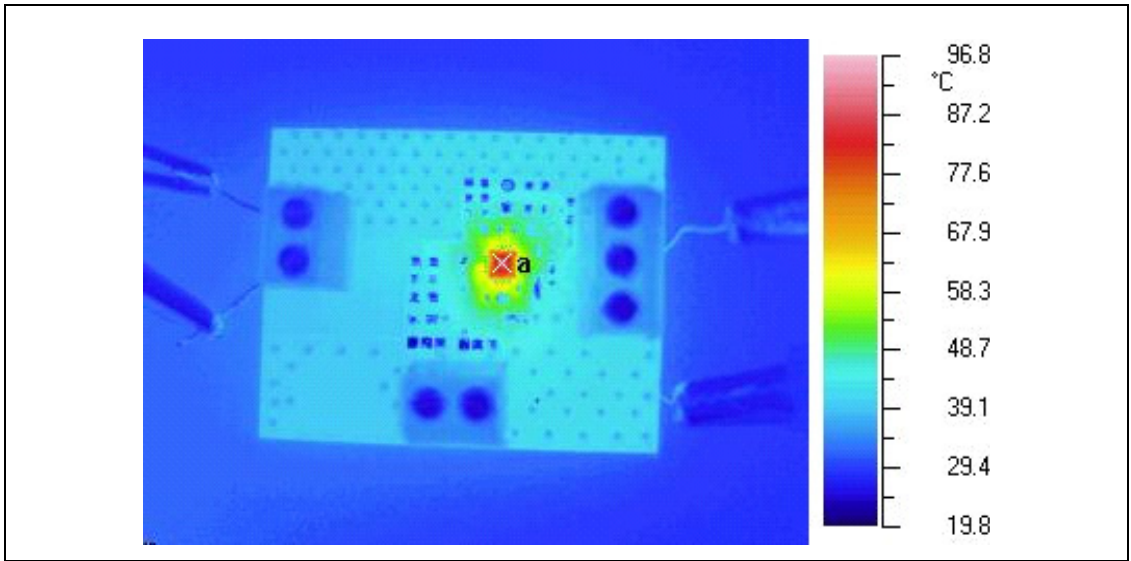
$$T_J = R_{THJ-A} \times P_{DISS} + T_{AMB} \quad \text{Eq: 10-1}$$

Where the R<sub>TH J-A</sub> of the device mounted on board is 75°C/W, the power dissipated is 1W, and the ambient temperature is 25°C.

In this case the junction temperature is:

$$T_J = 75 \times 1 + 25 = 100^\circ C \quad \text{Eq: 10-2}$$

Figure 24. Thermal image of the demo board



The  $V_{OSNS}$  pin can be used as a remote sense; so, it should be connected as closely as possible to the battery. The demo board layout and schematic are shown in [Figure 25](#) and [Figure 26](#).

Figure 25. Demoboard layout, top side

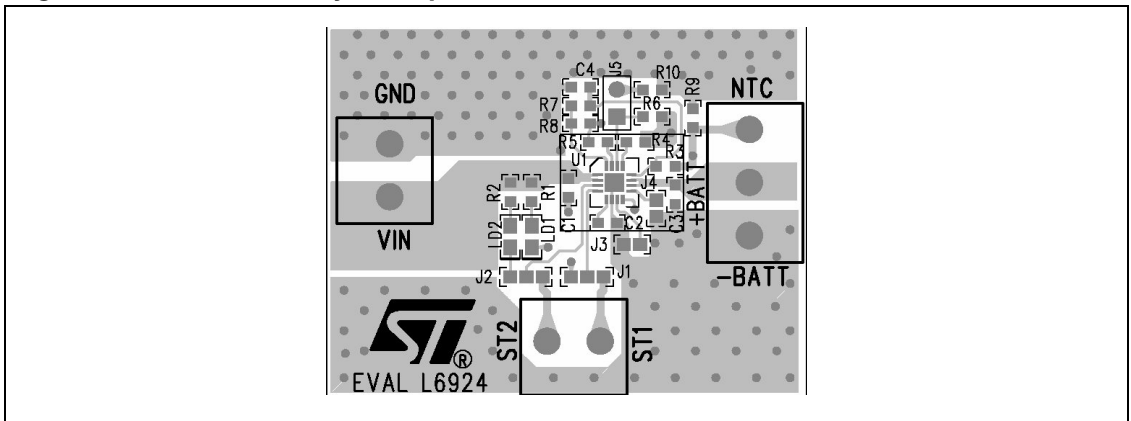


Figure 26. Demoboard layout, bottom side

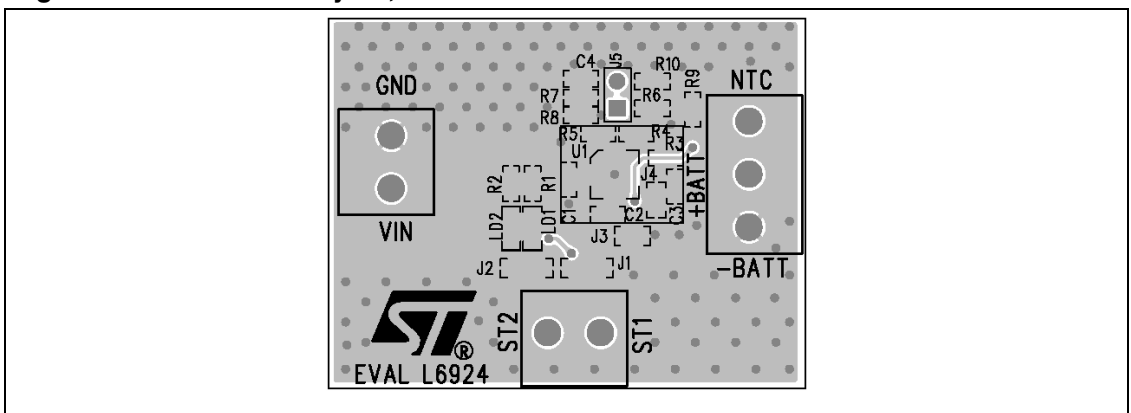


Figure 27. Demoboard schematic

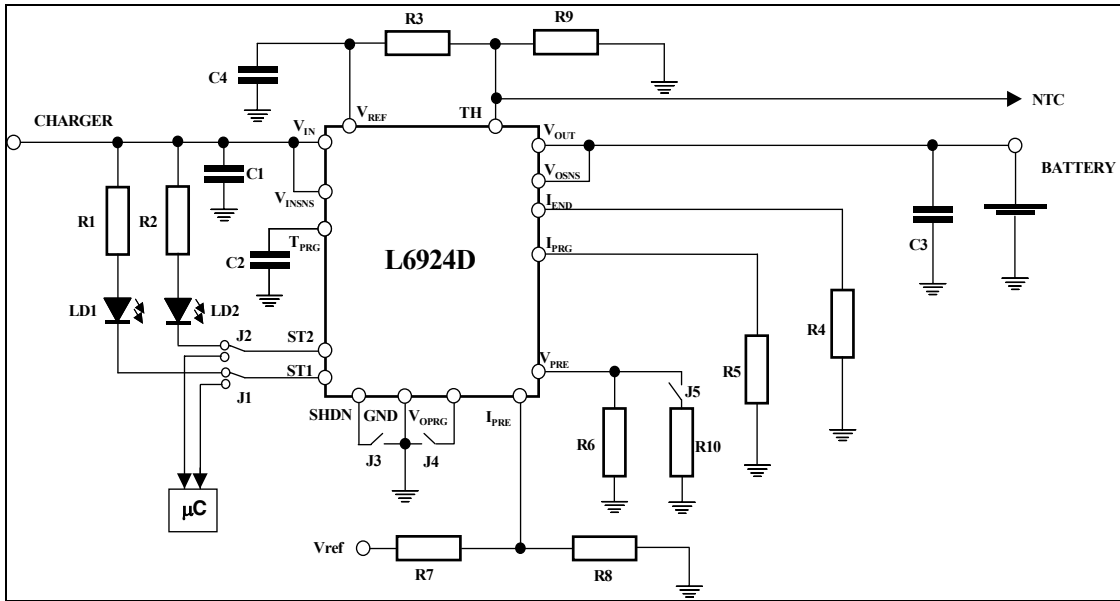


Table 7. Demo board components description

Name	Value	Description
R1	1K	Pull up resistor. To be used when the ST1 is connected with a LED.
R2	1K	Pull up resistor. To be used when the ST1 is connected with a LED.
R3	1K	Pull up resistor. Connected between V <sub>REF</sub> and TH pin.
R4	3K3	End of Charge current resistor. Used to set the termination current and, as a “Gas Gauge” when measuring the voltage across on it.
R5	24K	Fast-charge current resistor. Used to set the charging current.
R6	N.M.	V <sub>PRETH</sub> resistor. Used to set programmable pre-charge voltage threshold. If not mounted, the V <sub>PRETHDefault</sub> , equal to 2.8V, is set.
R7	N.M.	I <sub>PRETH</sub> resistor. Used to set the programmable pre-charge current threshold below the default one. If not mounted, the I <sub>PRETHDefault</sub> is set.
R8	68K	I <sub>PRETH</sub> resistor. Used to set the programmable pre-charge current threshold above the default one. If not mounted, the I <sub>PRETHDefault</sub> is set.
R9	470R	If a NTC is not used, a half value of R3 must be mounted to keep the TH voltage in the correct window.
R10	N.M.	It has the same function of R6. Moreover, if it is replaced with a short-circuit, when J5 is closed, the timer is reset (falling edge).
C1	1uF	Input capacitor.
C2	10nF	T <sub>MAX</sub> capacitor. Used to set the maximum charging time.
C3	4.7uF	Output capacitor.
C4	1nF	V <sub>REF</sub> filter capacitor.
LD1	GREEN	ST1 LED.



**Table 7. Demo board components description (continued)**

Name	Value	Description
LD2	RED	ST2 LED.
J1		ST1 jumper. Using to select the LED or the external $\mu\text{C}$ .
J2		ST2 jumper. Using to select the LED or the external $\mu\text{C}$ .
J3		SD jumper. If open, the device is in SD mode; when closed, the device starts to work.
J4		$V_{\text{OPRG}}$ jumper. If closed, the 4.2V output voltage is set; if open, the 4.1V is set.
J5		$V_{\text{PRE}}$ jumper. If closed with R10 in short-circuit with GND, reset the timer.

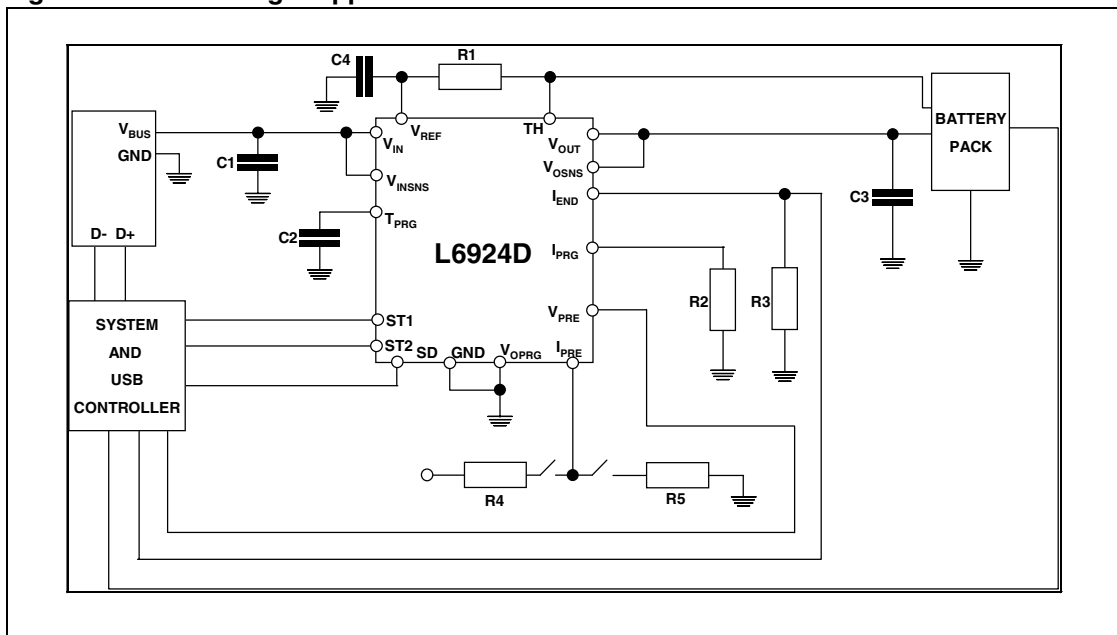
# 10 Application ideas

## 10.1 USB battery charger

With a voltage range between 4.75V and 5.25V, and a maximum current up to 500mA, the USB power bus is an ideal source for charging a single-cell Li-Ion battery. Since it is not possible to rely on the USB current limit to charge the battery, a linear approach must be adopted. Therefore, it is only necessary to set the  $I_{CHG}$  with a maximum value lower than 500mA, and the device will charge the battery in Linear mode.

Figure 28 shows an example of USB charger application schematic.

Figure 28. USB charger application



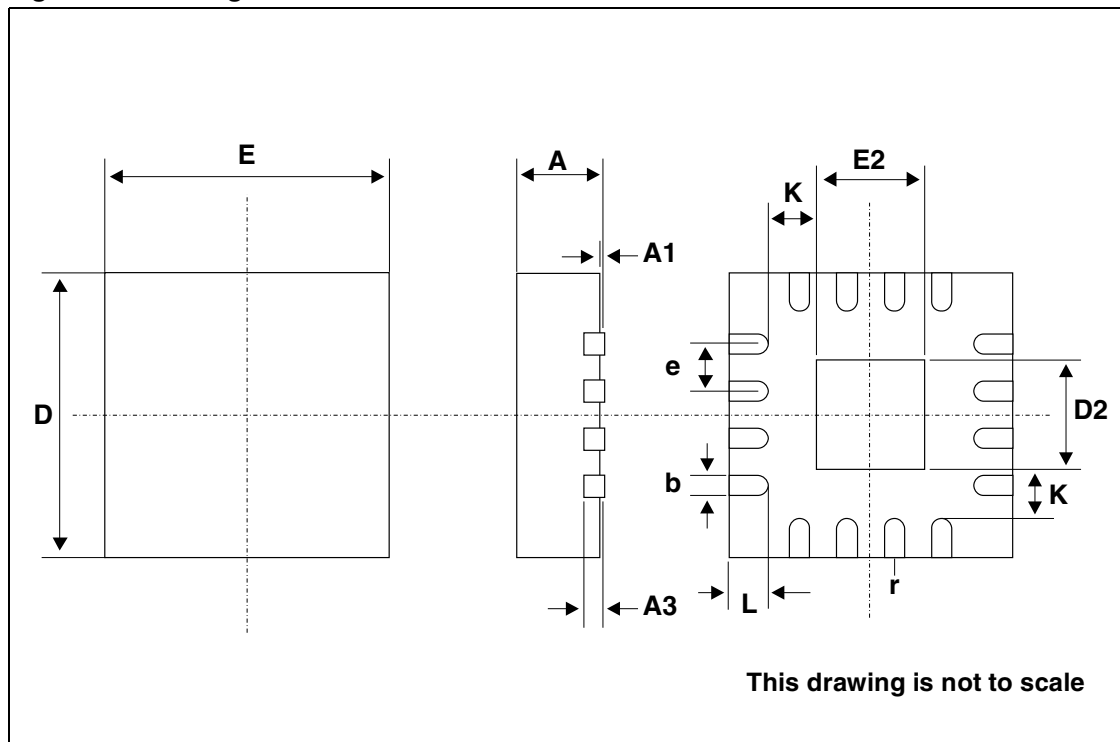
## 11 Package mechanical data

In order to meet environmental requirements, ST offers these devices in ECOPACK® packages. These packages have a Lead-free second level interconnect . The category of second Level Interconnect is marked on the package and on the inner box label, in compliance with JEDEC Standard JESD97. The maximum ratings related to soldering conditions are also marked on the inner box label. ECOPACK is an ST trademark. ECOPACK specifications are available at: [www.st.com](http://www.st.com).

Table 8. VFQFPN16 (3mm x 3mm) mechanical data

Dimensions						
Dim.	mm.			inch		
	Min.	Typ.	Max.	Min.	Typ.	Max.
A	0.800	0.900	1.000	0.031	0.035	0.039
A1		0.020	0.050		0.001	0.002
A2		0.650	1.000		0.025	0.039
A3		0.250			0.010	
b	0.180	0.230	0.300	0.007	0.010	0.012
D	2.875	3.000	3.125	0.113	0.120	0.123
D2	0.250	0.700	1.250	0.009	0.027	0.050
E	2.875	3.000	3.125	0.113	0.118	0.123
E2	0.250	0.700	1.250	0.009	0.027	0.049
e	0.450	0.500	0.550	0.017	0.019	0.021
L	0.300	0.400	0.500	0.011	0.015	0.019
ddd			0.080			0.003

Figure 29. Package dimensions



## 12 Revision history

**Table 9. Revision history**

Date	Revision	Changes
16-Dec-2005	1	First draft
20-Dec-2005	2	Package dimensions updated
10-Jan-2006	3	Few updates
14-Feb-2006	4	Part number updated
03-Jul-2006	5	Updates to formula in page 22, updated block diagram <a href="#">Figure 4</a> .
07-Sep-2006	6	Added <a href="#">Note: on page 22</a> , updated value C <sub>TPRG</sub> page 8
29-Jun-2007	7	Updated capacitor values C2, C3 in <a href="#">Table 7 on page 32</a>

**Please Read Carefully:**

Information in this document is provided solely in connection with ST products. STMicroelectronics NV and its subsidiaries ("ST") reserve the right to make changes, corrections, modifications or improvements, to this document, and the products and services described herein at any time, without notice.

All ST products are sold pursuant to ST's terms and conditions of sale.

Purchasers are solely responsible for the choice, selection and use of the ST products and services described herein, and ST assumes no liability whatsoever relating to the choice, selection or use of the ST products and services described herein.

No license, express or implied, by estoppel or otherwise, to any intellectual property rights is granted under this document. If any part of this document refers to any third party products or services it shall not be deemed a license grant by ST for the use of such third party products or services, or any intellectual property contained therein or considered as a warranty covering the use in any manner whatsoever of such third party products or services or any intellectual property contained therein.

**UNLESS OTHERWISE SET FORTH IN ST'S TERMS AND CONDITIONS OF SALE ST DISCLAIMS ANY EXPRESS OR IMPLIED WARRANTY WITH RESPECT TO THE USE AND/OR SALE OF ST PRODUCTS INCLUDING WITHOUT LIMITATION IMPLIED WARRANTIES OF MERCHANTABILITY, FITNESS FOR A PARTICULAR PURPOSE (AND THEIR EQUIVALENTS UNDER THE LAWS OF ANY JURISDICTION), OR INFRINGEMENT OF ANY PATENT, COPYRIGHT OR OTHER INTELLECTUAL PROPERTY RIGHT.**

**UNLESS EXPRESSLY APPROVED IN WRITING BY AN AUTHORIZED ST REPRESENTATIVE, ST PRODUCTS ARE NOT RECOMMENDED, AUTHORIZED OR WARRANTED FOR USE IN MILITARY, AIR CRAFT, SPACE, LIFE SAVING, OR LIFE SUSTAINING APPLICATIONS, NOR IN PRODUCTS OR SYSTEMS WHERE FAILURE OR MALFUNCTION MAY RESULT IN PERSONAL INJURY, DEATH, OR SEVERE PROPERTY OR ENVIRONMENTAL DAMAGE. ST PRODUCTS WHICH ARE NOT SPECIFIED AS "AUTOMOTIVE GRADE" MAY ONLY BE USED IN AUTOMOTIVE APPLICATIONS AT USER'S OWN RISK.**

Resale of ST products with provisions different from the statements and/or technical features set forth in this document shall immediately void any warranty granted by ST for the ST product or service described herein and shall not create or extend in any manner whatsoever, any liability of ST.

ST and the ST logo are trademarks or registered trademarks of ST in various countries.

Information in this document supersedes and replaces all information previously supplied.

The ST logo is a registered trademark of STMicroelectronics. All other names are the property of their respective owners.

© 2007 STMicroelectronics - All rights reserved

STMicroelectronics group of companies

Australia - Belgium - Brazil - Canada - China - Czech Republic - Finland - France - Germany - Hong Kong - India - Israel - Italy - Japan - Malaysia - Malta - Morocco - Singapore - Spain - Sweden - Switzerland - United Kingdom - United States of America

[www.st.com](http://www.st.com)